





# I nostri clienti



**Amministrazione:** Consigli comunali, Ministeri, Ambasciate, Prefetture, Istituti penali



**Banche e assicurazioni**



**Commercio e Industria:** Renault, Peugeot, Citroën, Christian Dior, Dassault, Givenchy



**Energia**



**Edifici Pubblici**





# I nostri clienti



**Ospedali**



**Trasporti**



**Scuole**



**Hotel**



**Telecomunicazioni**





## L'organigramma



- Un sistema masterkey vi permetterà di organizzare gli accessi all'interno per assicurarvi che le uniche persone autorizzate possano entrare negli unici locali autorizzati
- La tecnologia Dény Security è una delle più potenti sul mercato in termini di capacità combinatoria
- Cilindro Deny è un prodotto di alta sicurezza ed è apprezzato per la sua resistenza agli ambienti difficili (sabbia, umidità...ecc.) e duraturo



## Esperto del mercato ferroviario

- Sviluppo di nuovi prodotti secondo le vostre specifiche.
- Vi forniremo consulenza proattiva su qualsiasi problema relativo al controllo degli accessi e alla sicurezza.
- Un team dedicato al mercato ferroviario



# Esperto del mercato ferroviario

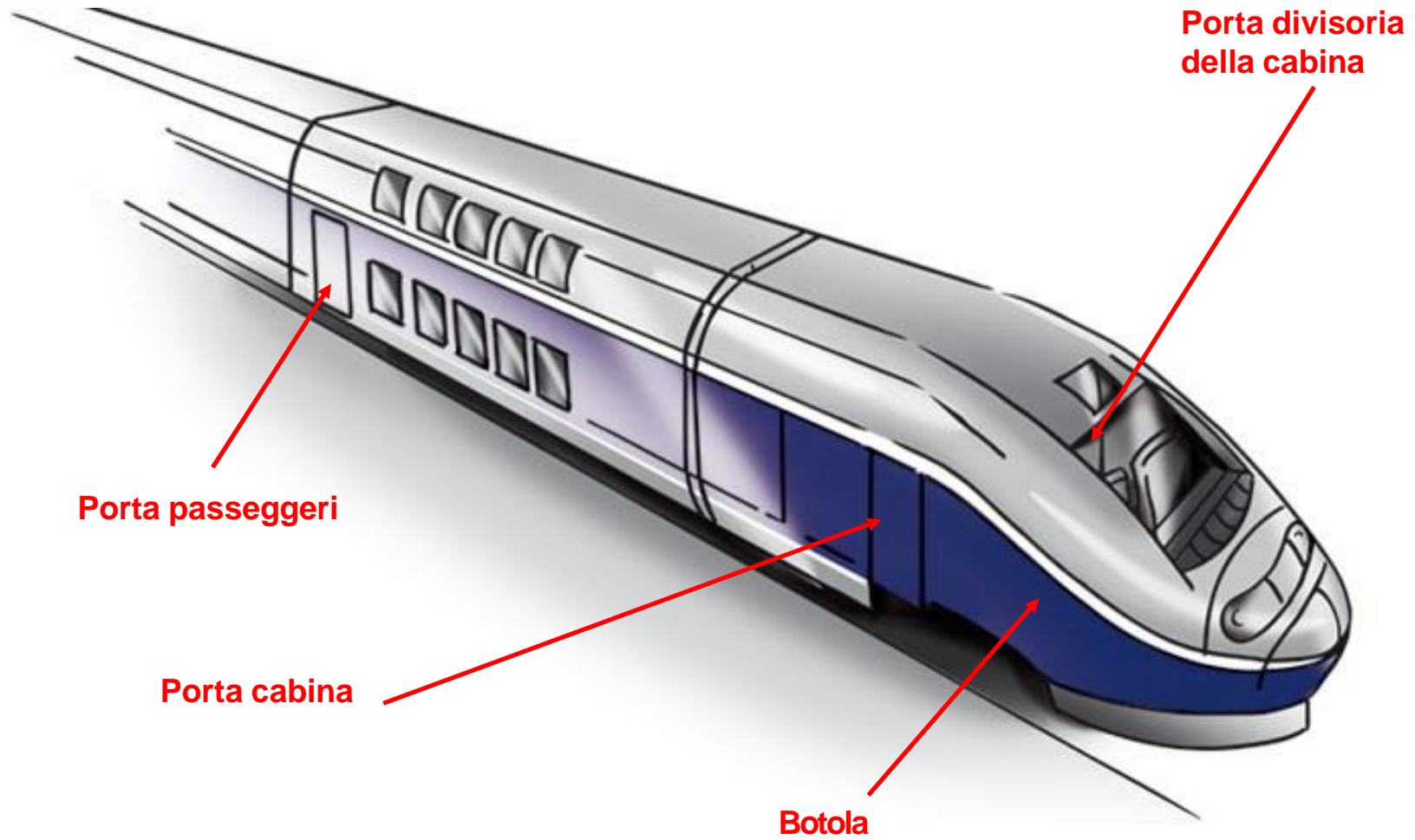



# Expert of the railway market

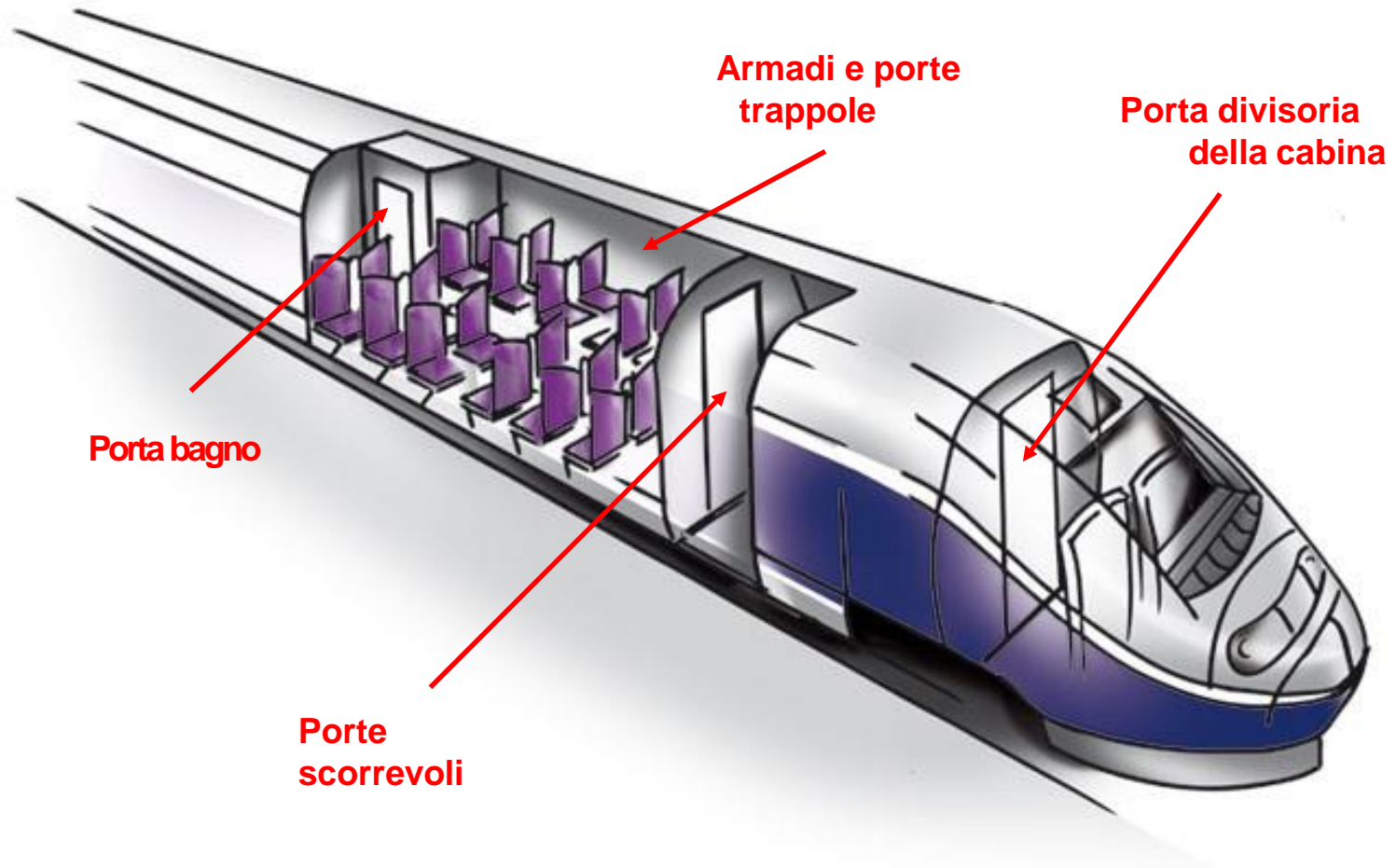



# Le nostre soluzioni per veicoli ferroviari

## Porta divisoria della cabina

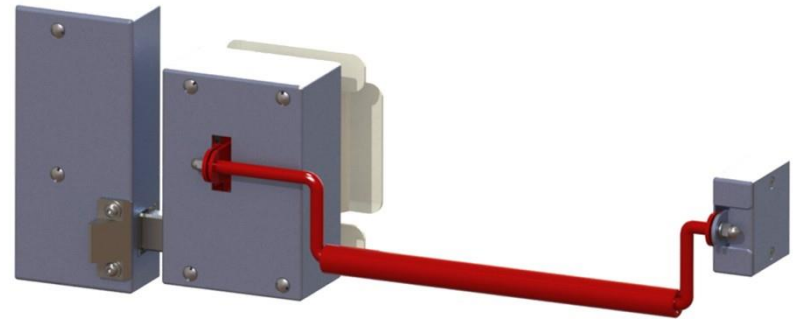





# Le nostre soluzioni per veicoli ferroviari

## Porta divisoria della cabina

- Serratura progettata per la porta a due vie per la porta divisoria della cabina
- Funzionamento tramite lettore di schede e/o chiave Dény
- Conforme alle nuove esigenze dei clienti (norma SNCF, EN1125)
- Sistema anti-vandalismo
- Dény Security ha progettato il prodotto e produce l'intero prodotto nel suo impianto (compreso il cilindro)

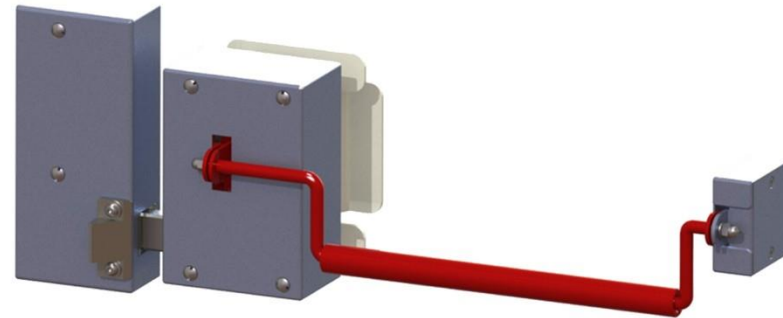



# Le nostre soluzioni per veicoli ferroviari

## Porta divisoria della cabina

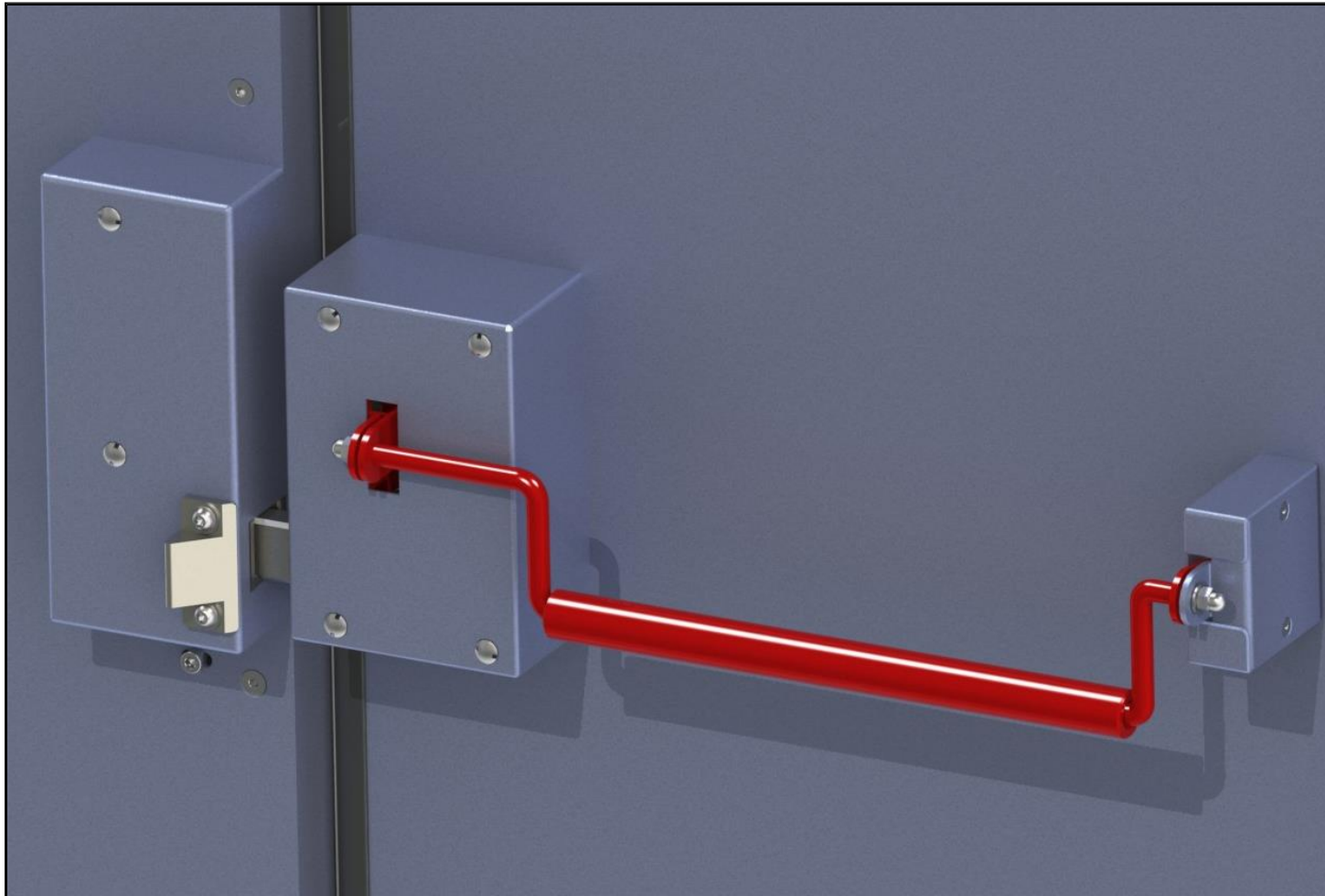



# Le nostre soluzioni per veicoli ferroviari

## Porta divisoria della cabina





# Le nostre soluzioni per veicoli ferroviari

## Porta divisoria della cabina

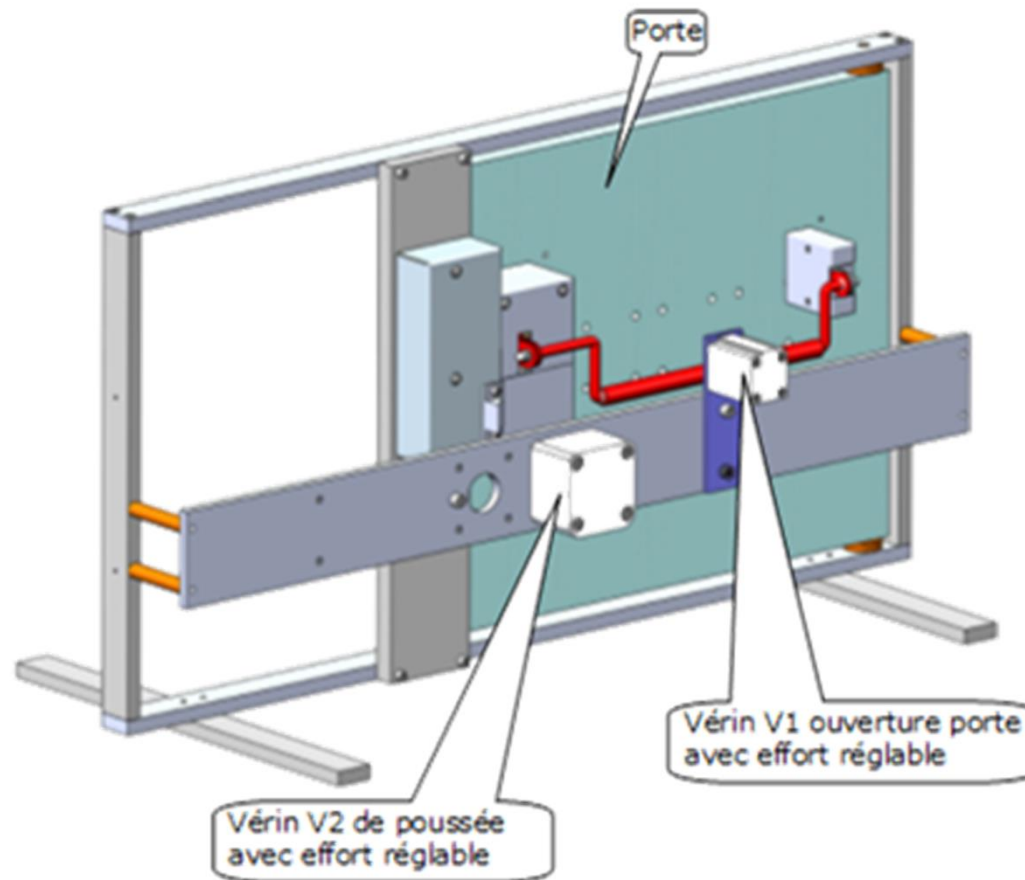



# Le nostre soluzioni per veicoli ferroviari

## Porta divisoria della cabina





# Le nostre soluzioni per veicoli ferroviari

## Porta divisoria della cabina

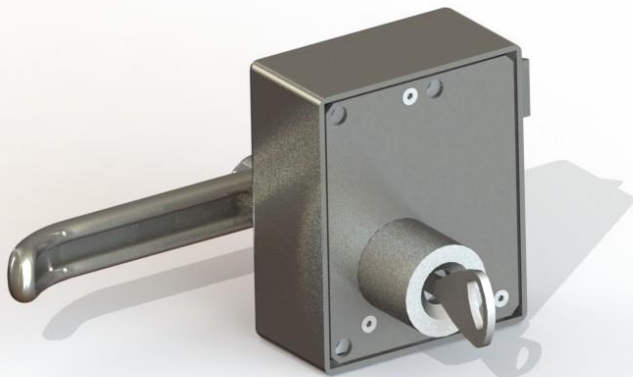
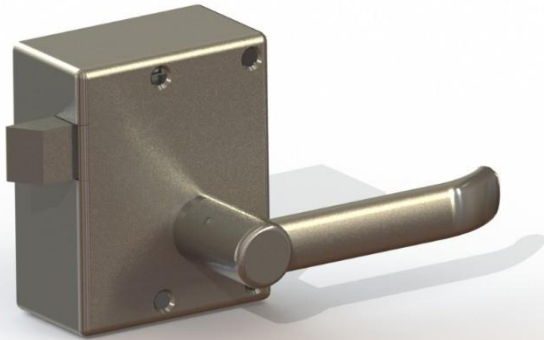

- Porta divisoria della cabina PRASA (Sud Africa)
- Chiave secondo il requisito del cliente
- Nuovo design secondo le specifiche tecniche del cliente
- Porta con forte tenuta



# Le nostre soluzioni per veicoli ferroviari

## Porta divisoria della cabina

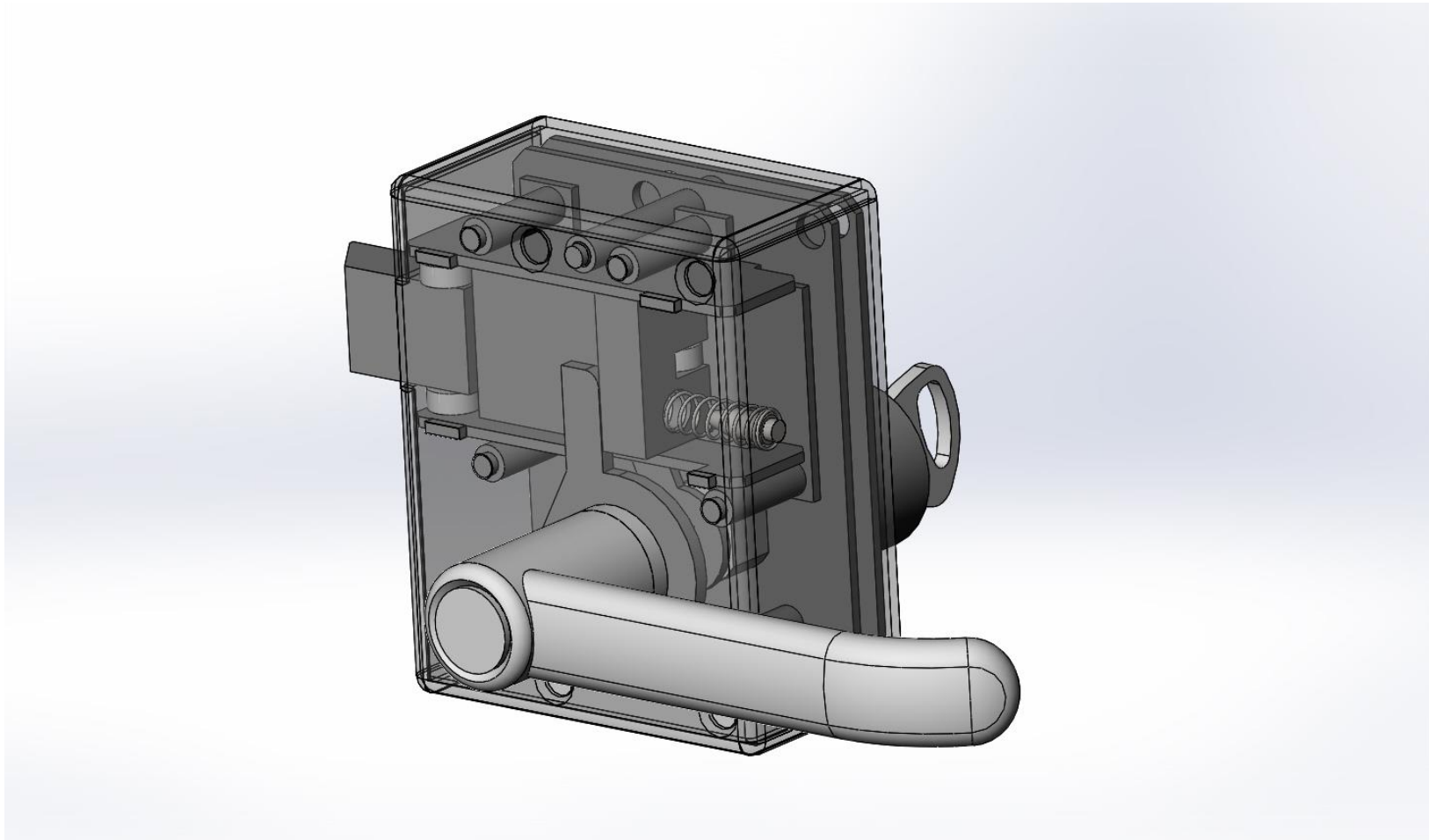



# Le nostre soluzioni per veicoli ferroviari

## Porta divisoria della cabina

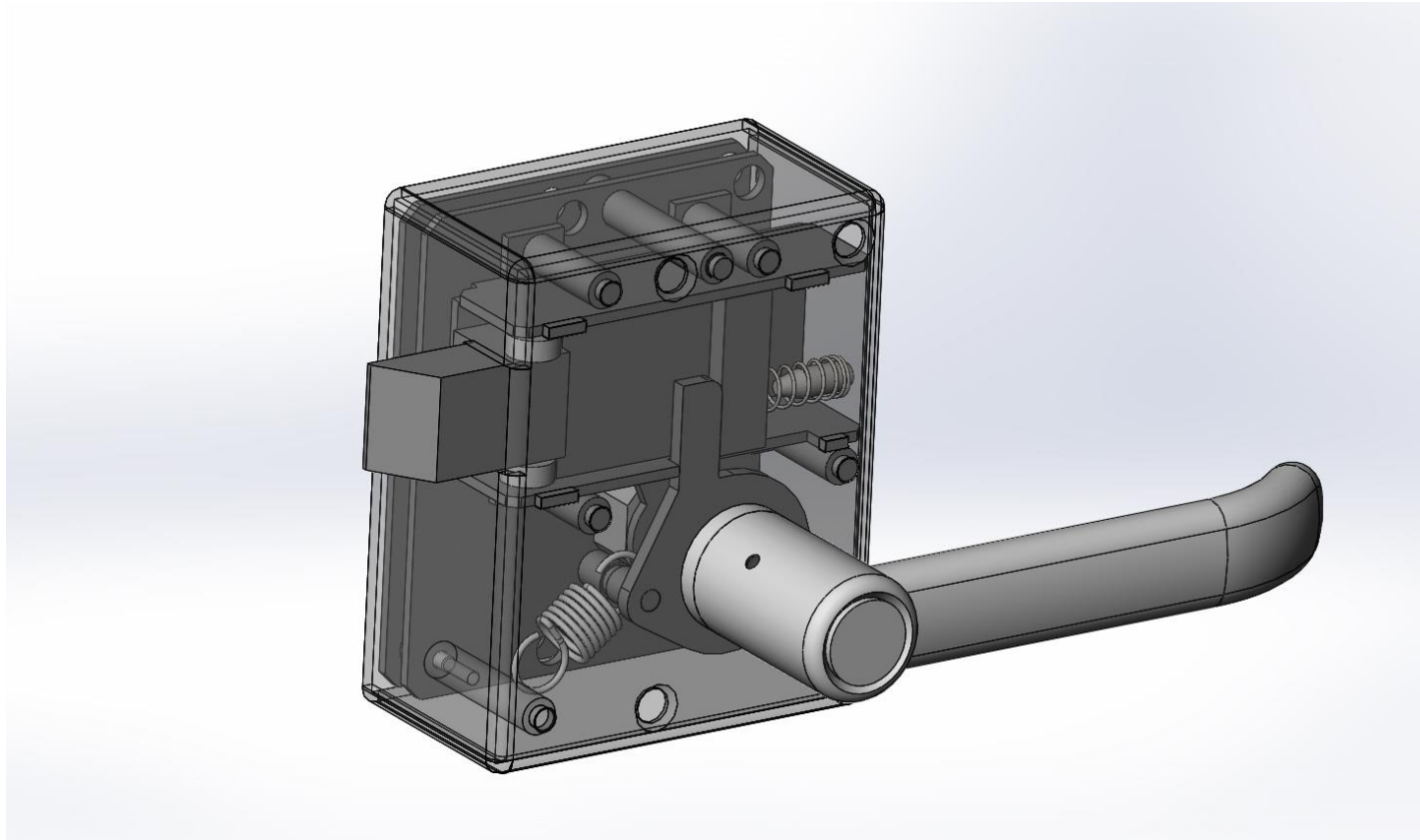





# Le nostre soluzioni per veicoli ferroviari

## Porta divisoria della cabina

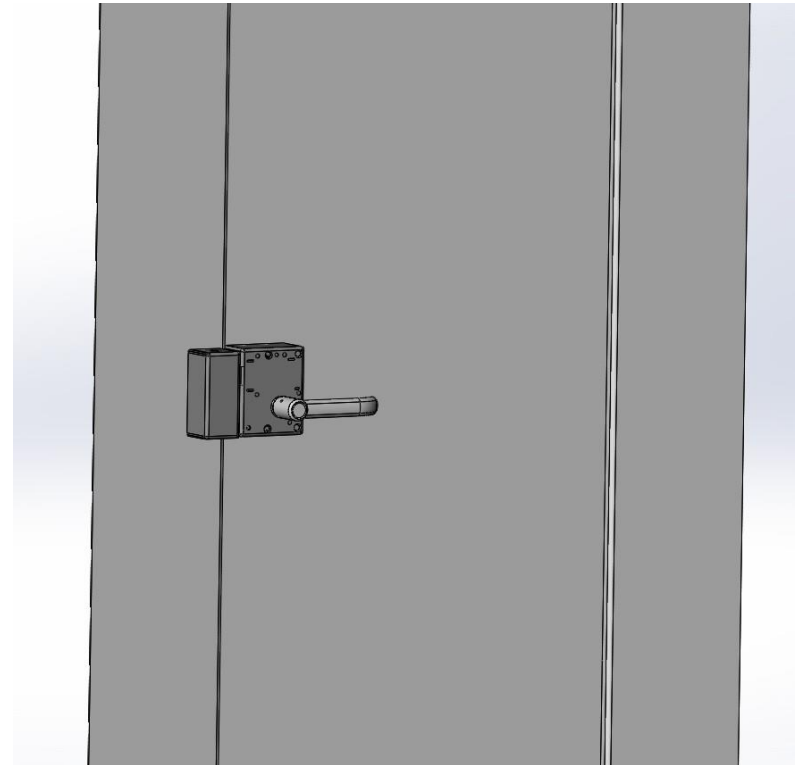
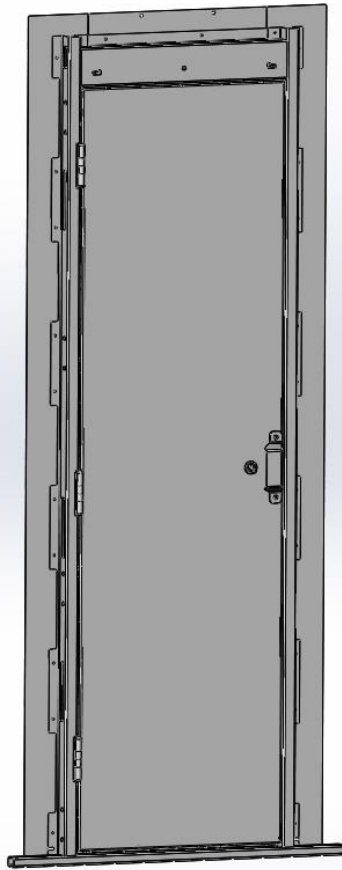



# Le nostre soluzioni per veicoli ferroviari

## Porta divisoria della cabina





# Le nostre soluzioni per veicoli ferroviari

## Porta divisoria della cabina

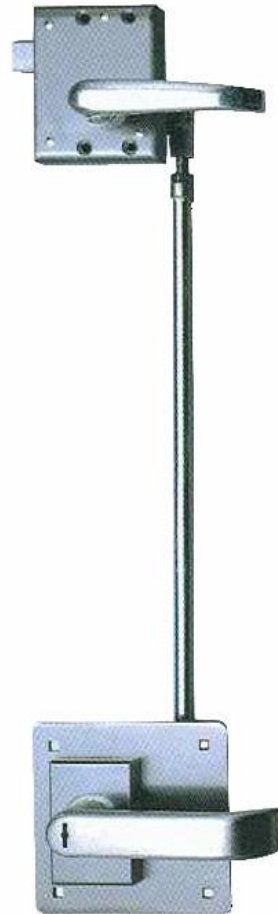



# Le nostre soluzioni per veicoli ferroviari

## Porta scorrevole





# Le nostre soluzioni per veicoli ferroviari

## Porta del bagno





# Le nostre soluzioni per veicoli ferroviari

## Porta del bagno



- STI PMR blocco meccanico
- Indicatori tattili PMR
- Conformità al brevetto SNCF



# Le nostre soluzioni per veicoli ferroviari

## Botola



- Botola conforme alle specifiche SNCF (una sola disponibile sul mercato)
- Sistema di apertura 12.
- Cassa in plastica disponibile
- Prodotto in Francia



# Le nostre soluzioni per veicoli ferroviari

## Botola e armadi







## Le nostre soluzioni per veicoli ferroviari **Botola e armadi**

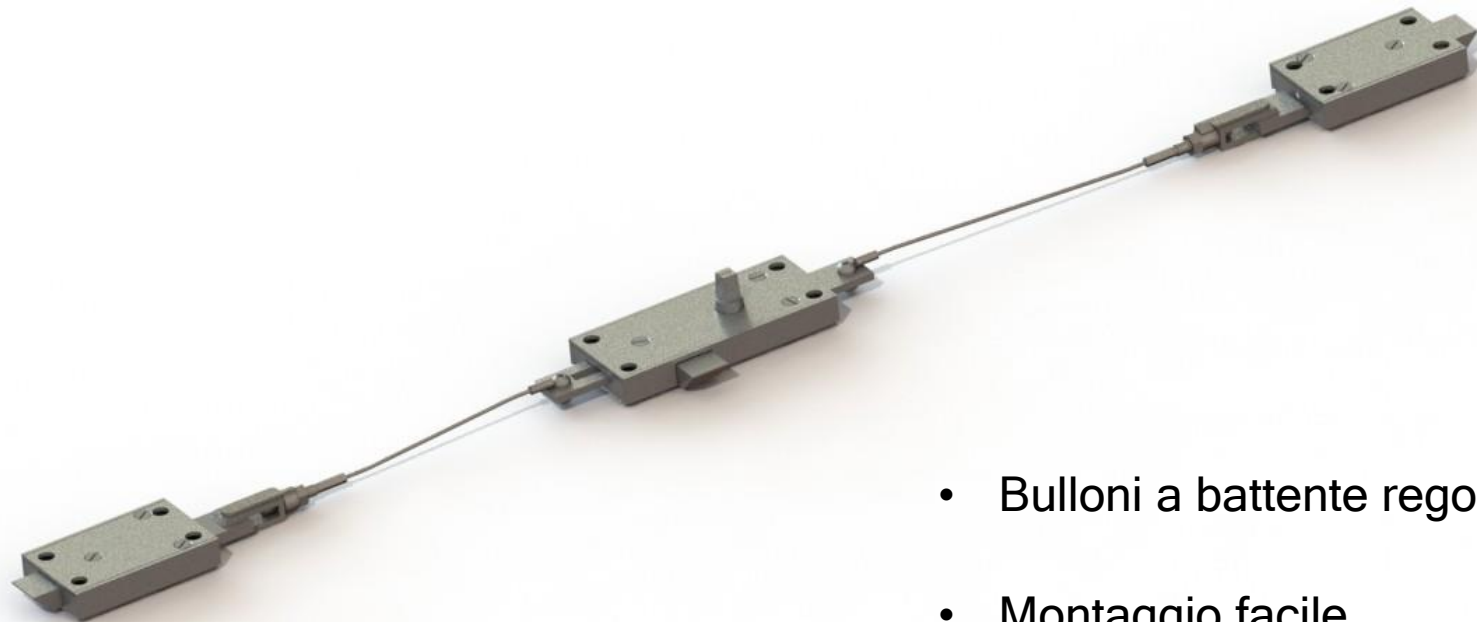

- Bulloni a battente regolabili
- Montaggio facile
- Chiave quadrata o chiave di sicurezza



# Le nostre soluzioni per veicoli ferroviari

## Botola e armadi

